

# RELIABLE PERFORMANCE IN FILTERING SYSTEMS



be  
think  
innovate

**GRUNDFOS** 

# THE MTA RANGE IMMERSIBLE PUMPS FOR FILTERING SYSTEMS

Grundfos' MTA range of single-stage immersible pumps are designed especially for filtering systems in the machine tool industry. The low-pressure pumps are available in 9 different flow variants, offered with a choice of bottom suction or suction from the top of the volute.

## Multiple applications

The compact MTA pumps efficiently transport liquid containing chips, fibres and abrasive particles on to the filtering unit. Semi-open impellers allow the passing of chips up to 0.4 in (10 mm) making the pumps ideal for removing liquid from any machining process – from boring and milling to grinding.

## High-quality materials

Carefully chosen materials ensure trouble-free operation and long life. The top of the pump is made of cast iron, while the impeller is available in composite or bronze. Composite is used in MTA pumps with flow up to 79.25 gpm (300 l/min). In the bigger pumps with higher flow the impellers are made of bronze to ensure perfect resistance to e.g. metal chips. As the pumped liquid will always contain oil there is no risk of corrosion.

## Easy installation

Easy installation is another of the benefits of the MTA pumps. The tank-mounting flange dimensions have been carefully designed to ensure that even replacements of competing products can be replaced easily. No special tools are required for the installation of the MTA pumps – just as the entire range is easily serviced and cleaned.

## Full-line supplier

In addition to the MTA range for filtering systems, Grundfos offers a wide range of pumps for the cooling and cleaning of tools inside the machine. This allows you the benefit of convenient and time-saving one-stop shopping.

## TECHNICAL DATA

Description	Motor size Watt	Immersible length						Suction type		Pipe connection RP/NPT
		130	150	180	250	280	350	Bottom	Top	
MTA30	100		X					X	X	1/2"
MTA60	180	X		X	X		X	X	X	3/4"
MTA90	250	X		X	X		X	X	X	3/4"
MTA120	400			X	X	X	X	X	X	1 1/4"
MTA200	750				X	X	X	X		1 1/2"
MTA20H	100		X						X	1/2"
MTA40H	180			X					X	3/4"
MTA70H	250				X			X	X	3/4"
MTA100H	400					X			X	1"

Voltage variants 3x230/400V 50/60Hz  
3x200/346V 50/60Hz  
3x230/460V 60Hz

MTA

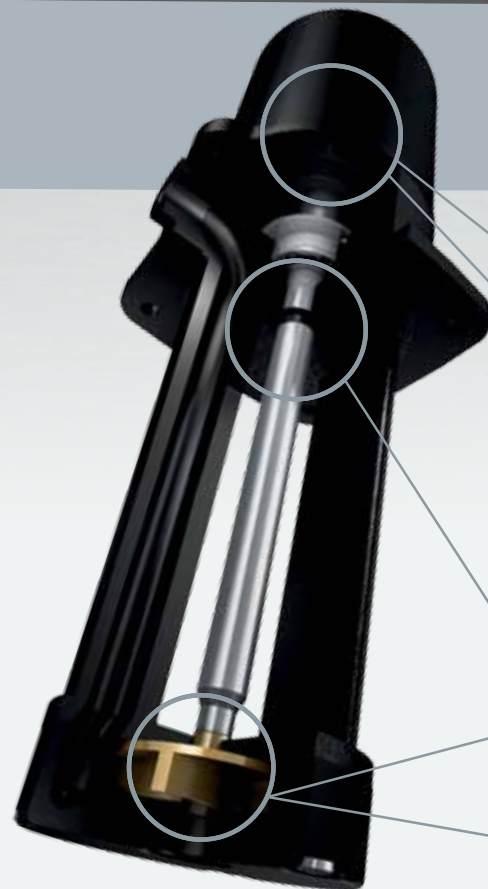

## MTA FEATURES AND BENEFITS

**High-efficiency motor and hydraulic**  
Low operational costs

**Long bearing lifetime**  
Maintenance-free

**No shaft seal**  
Prevents leakages

**Bottom or top suction**  
Suction option for different demands

**Semi-open impeller**  
Ensures free passage of solids and chips

## PERFORMANCE CURVES

■ MTA-H ■ MTA

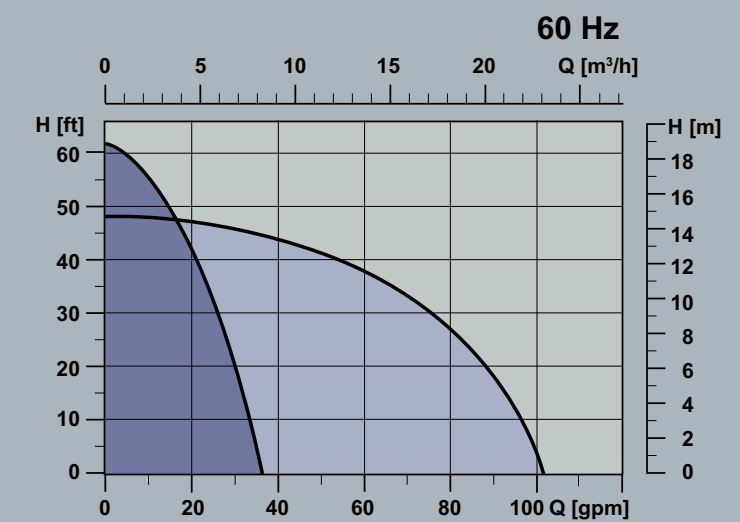
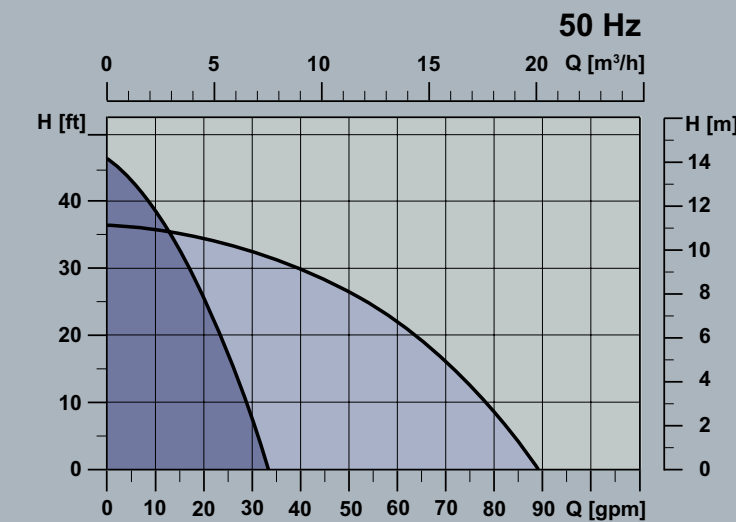

## The Grundfos MTA range

The single-stage immersible pumps that make up the Grundfos MTA range represent the low pressure area in the machine tool applications. With their semi-open impellers they are capable of pumping liquids containing solids, fibres and chips.

Applications:

- Boring
- Sawing
- Milling
- Cooling
- Grinding

Explore the impressive Grundfos portfolio at [www.grundfos.us](http://www.grundfos.us)

L-MTA-SL-01 Rev. 06-13

**GRUNDFOS Kansas City**  
17100 West 118th Terrace  
Olathe, Kansas 66061  
Phone: (913) 227-3400  
Fax: (913) 227-3500

**GRUNDFOS Canada**  
2941 Brighton Road  
Oakville, Ontario  
L6H 6C9  
Phone: (905) 829-9533  
Fax: (905) 829-9512

**GRUNDFOS Mexico**  
Boulevard TLC No. 15  
Parque Industrial Stiva Aeropuerto  
C.P. 66600 Apodaca, N.L. Mexico  
Phone: 011-52-81-8144 4000  
Fax: 011-52-81-8144 4010

[www.grundfos.us](http://www.grundfos.us)

[www.grundfos.ca](http://www.grundfos.ca)

[www.grundfos.mx](http://www.grundfos.mx)

The name Grundfos, the Grundfos logo, and be think innovate are registered trademarks owned by Grundfos Holding A/S or Grundfos A/S, Denmark. All rights reserved worldwide.

**GRUNDFOS** 